



INSTRUCTION MANUAL FOR THE STRINGING MACHINE MS140N and MS140L.
concept

CONTENTS:

A. TO PREPARE THE MACHINE FOR USE.

- A1. Fastening the cross legs
- A2. Clamping the machine to the table.
- A3 Fastening the lever of the drop weight system.
- A4. Mounting the turntable over the shaft.
- A5. Calibrating the tension system.
- A6. End of stroke indication.
- A7. Rotate the knob on the Tension handle.

B. THE OPERATION OF THE MACHINE.

- B1 Adjusting the tension.
- B2. To pull tension on a string.
- B3. The racquet support / clamp system
- B4. Mounting a racquet.
- B5. Using the table lock.
- B6. Using the clamp systems.
- B6a Using flying clamps TH.
- B6d Checking the clamp adjustment.

C. OUT OF USE AND TO TRANSPORT THE MACHINE.

- C1. Out of use or transporting the machine.
- C2. Mounting the machine in the travel case.

D. THE MAINTENANCE OF THE MACHINE.

- D1. Cleaning the string clamp of the tension unit
- D2. Cleaning the clamps
- D3. Adjusting and lubricating the turntable.

E. Overhaul of a Stringway clamp.

A. TO PREPARE THE MACHINE FOR USE.

A1. Fastening the cross legs

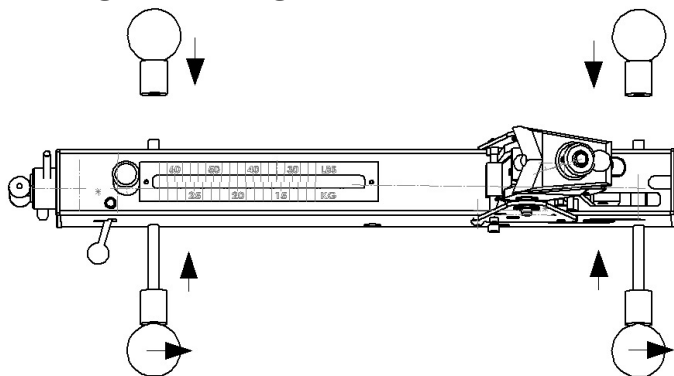

Put the cross leg screws through the frame and the second bush and tighten the ball knob firmly.

A2. Clamping the machine to the table.

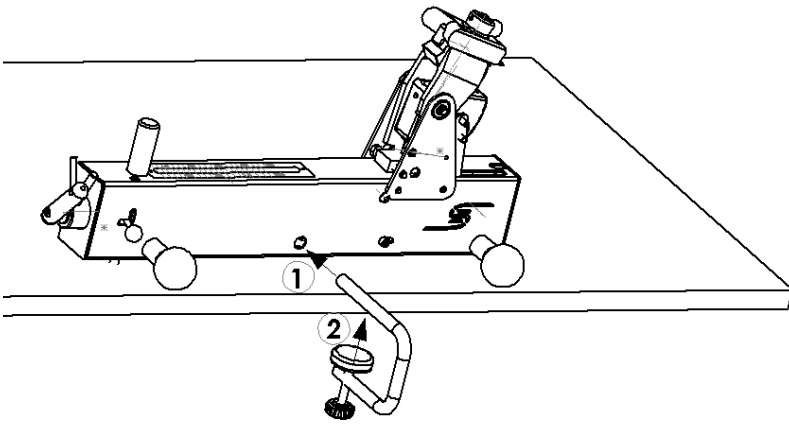

The machine can only be used when it is clamped to the table. Slide the table clamp through the frame and position the machine so far from the edge of the table that the clamping screw is under the centre of the frame. Tighten the clamping screw firmly.

A3 Fastening the lever of the drop weight system.

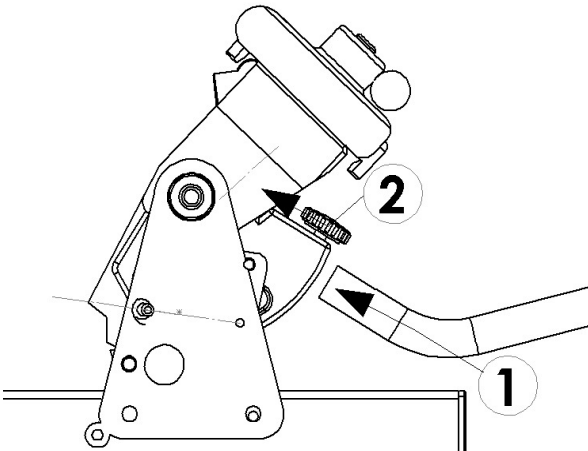

Loosen the clamping screw a little and slide the lever into the tension head with the screw in the slot. Tighten the clamping screw. On later machines the ratchet screw is replaced by an Alan Bolt.

A4. Mounting the turntable over the shaft.

Slide the turntable over the shaft. Check if there is grease inside the delrin bush, if not add a thin layer of grease into the bearing.

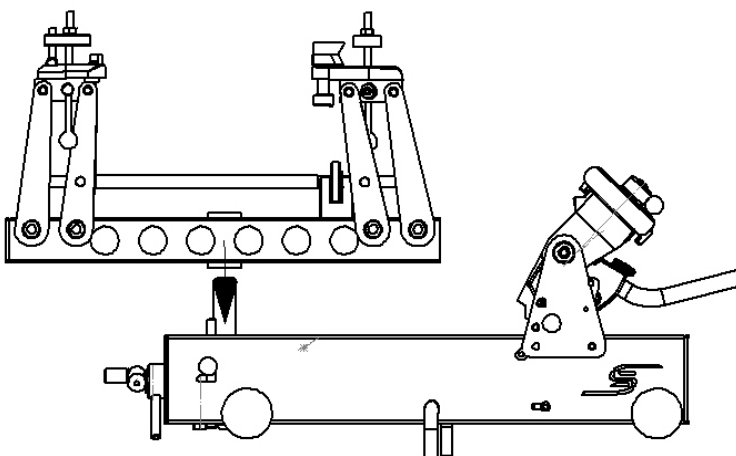

A5. Calibrating the tension system.

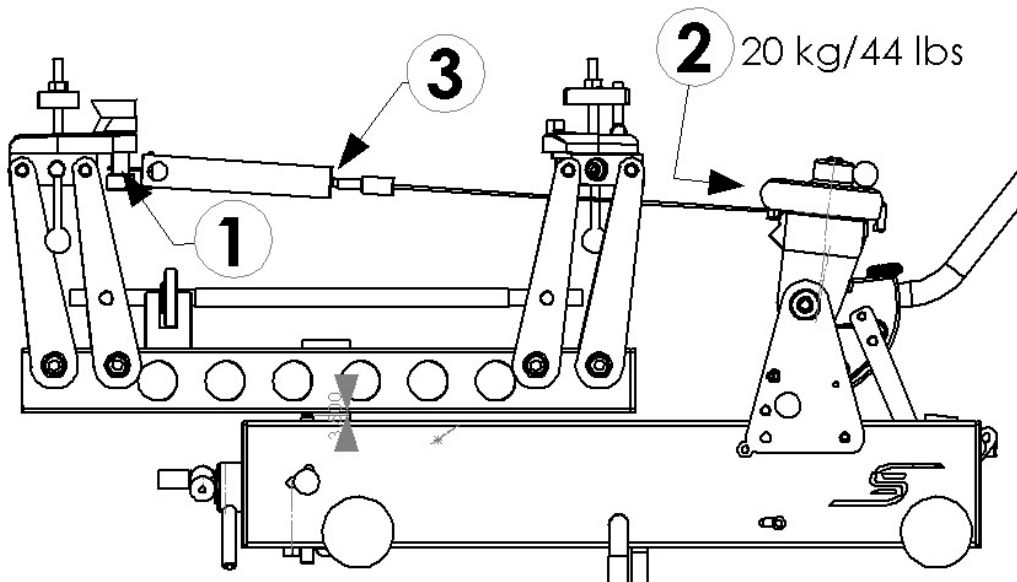

The tension system can be calibrated with the calibrator which is supplied with the machine. The tension will not vary more than a few percent over the hole stroke. To get the most accurate results calibrate the system in the middle of the stroke between the forward position and the moment that the “end of stroke signal” starts to move.

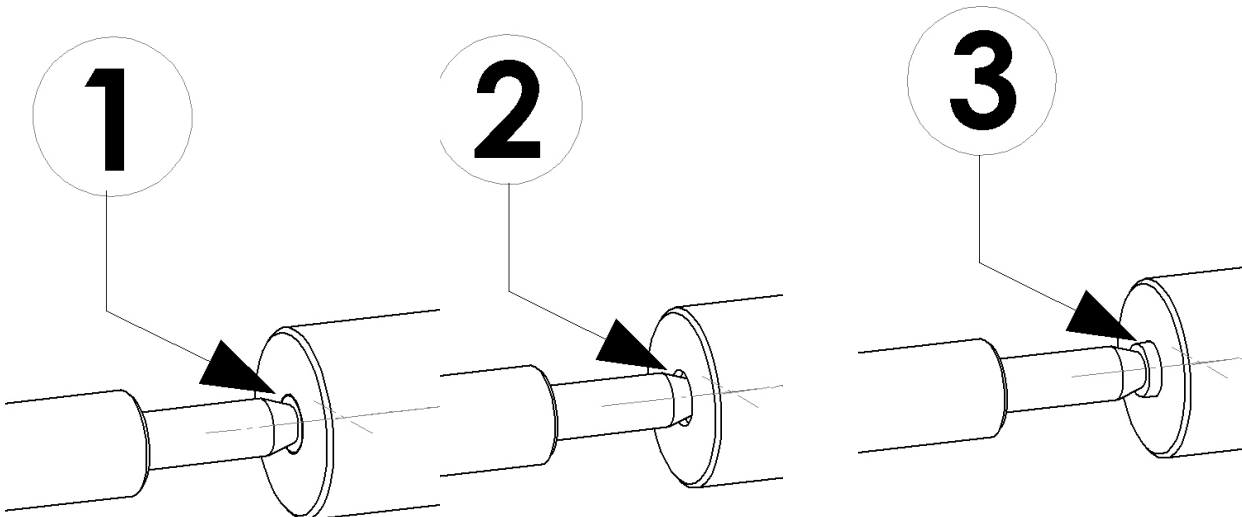

Adjust the tension at 20 kg / 44 lbs and attach the tensioner to one of the adjusting bolts as shown in the picture. Lock the turntable with the calibrator parallel with the main frame.

Tension the string of the calibrator and watch the pull rod of the calibrator:

- In situation 1 the tension is correct, the end of the marks is level with the end of the red housing.
- In situation 2 the tension too low, the end of the marks is still inside the housing.
- In situation 3 the tension is too high.

To adjust the tension.

The tension can be adjusted with the bolt that moves out of the housing when the tension arm is lifted to the maximum. Turn the hexan bolt clockwise to raise the tension and anti clockwise to lower it.

IMPORTANT:

- Turn the calibration bolt only while you lift the lever to bring the tension head to the starting position.
- The tension must be calibrated when the tension head is in that part of stroke where it is used during stringing.
- Take care that the “end of stroke indication is not out during the calibration
- Check the tension after every adjustment by lowering the lever.

A6. End of stroke indication.

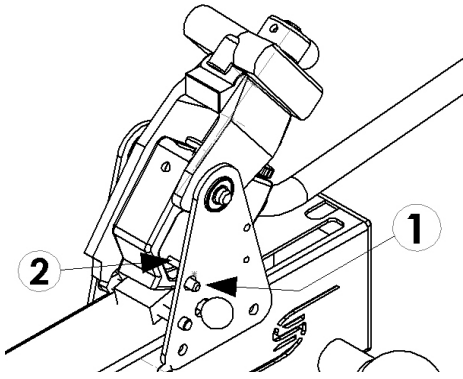

At the end of the stroke the tension drops.
When the “end of stroke indicator” moves out, tension the string again:
Lift the lever to open the jaws, pull the string tight and lower the lever again.

IMPORTANT: A string needs less stretch when it is pulled for the second time because the remaining elongation from the first pull is already developed.

A7. Rotate the knob on the Tension handle.

For transport the knob on the tension handle can be rotated.
Loosen the Alan bolt and rotate it parallel with the main frame before you start stringing.

B. THE OPERATION OF THE MACHINE.

B1 Adjusting the tension.

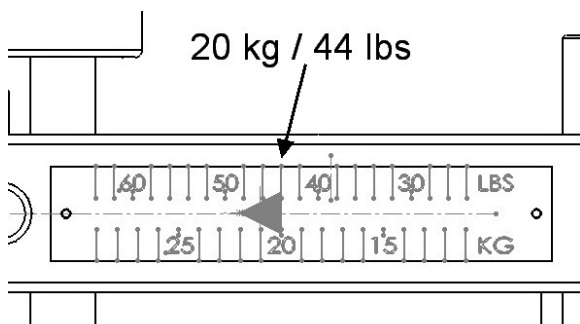

* The tension can be adjusted between 18 and 28 kg or 32 and 62 lbs. The machine can string up to 32 kg or 72 lbs by adding the extra (badminton) weight.

The weight can be adjusted with the handle and the scale.

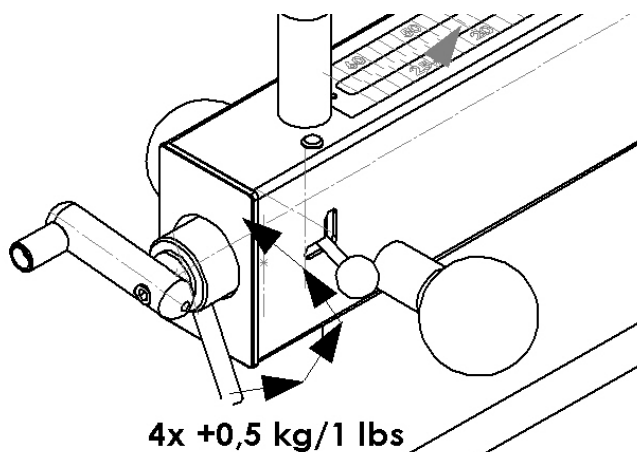

On the MS140L the tension can be raised or lowered in 4 steps of 0,5 kg (1 lbs) with the handle behind the adjusting handle.

B2. To pull tension on a string.

* The locking system:

The MS140L and N have an automatic locking system on the tension head;

- The tension head is locked in the starting position when no string is clamped in the tension head.
- The lock must be released by hand.

* Inserting the string in the string clamp.

- Lift the lever to open the string clamp.
- The string can be clamped at the front or at the back or both for vulnerable strings.
- Around the back of the system is the easiest and most certain way.
- Pull the string straight along the bottom side of the upper jaw and pull it into the slot between the upper and the lower clamping surface.
- Release the lock by pushing down the release knob.
- Lower the lever to clamp the string.

Always take good care that the string lies against the cams of the upper jaw when the string is clamped!

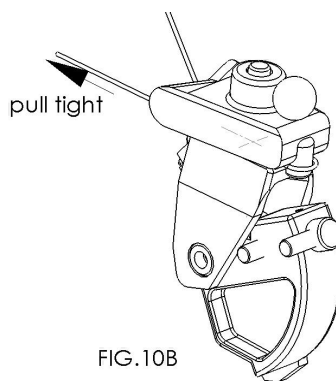
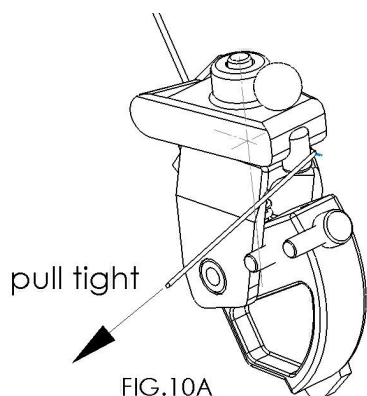

“TO DOUBLE CLAMP THE STRING” (fig. 10B)

To lower the pressure on the string it can also be clamped “double” using the front and the backside of the string clamp:

- Wrap the string around the tension head.
- Lift the lever to open the string clamp.
- Pull the string straight towards the front.
- Move the string into the clamp at the front side.
- Lower the tension lever.

B3. The racquet support / clamp system

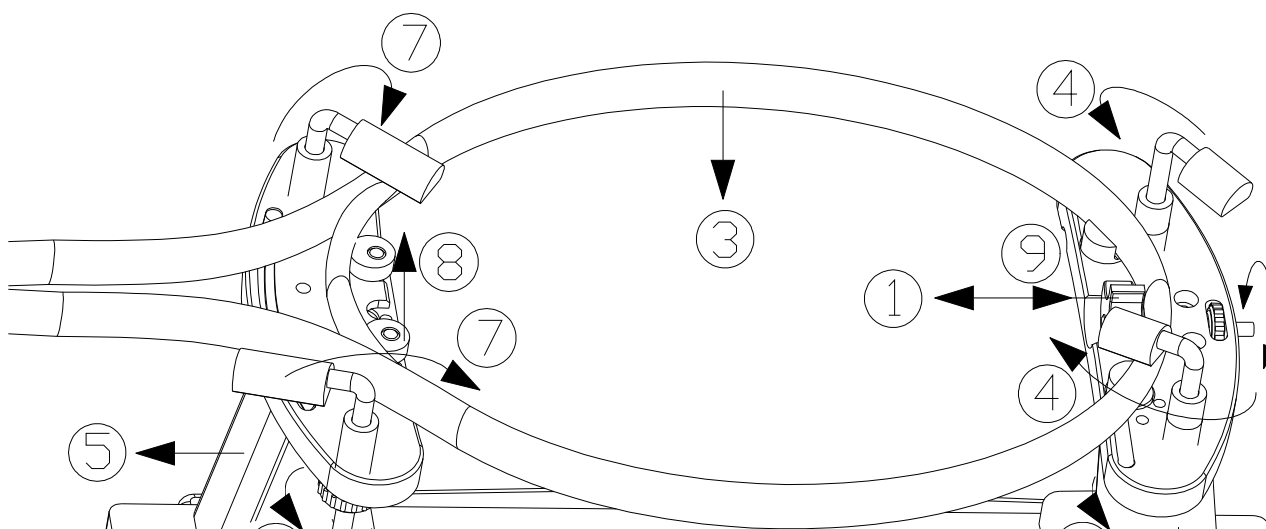

B3. Mounting a tennis racquet

It is not necessary to mount the racquet in the middle of the turntable, Leave the head support at one

end of the table and move the throat support up and down to adjust it to the size of the racquet. Mounting a tennis racquet goes as follows, the numbers in figure 11 show the sequence of the actions.

- 1) Move the central head support inwards.
- 2) Move the throat support inwards so that the racquet fits over the supports.
- 3) Put the racquet on the support plates, with the central main string positions at each side of the central support. Place the racquet against the inside supports.
- 4) Put the clamping hooks at the head side on the racquet and turn the knob upwards so that the racquet can not move off the plate.
- 5) Move the throat side post outwards until the flat side of the supports lie against the racquet
- 6) Fix the throat side post in that position with the clamping knob at the bottom.
- 7) Put the clamping hooks at the throat side on the racquet and tighten all clamping hooks.
- 8) Adjust the throat side supports upwards until they lie 2 mm below the tubes in the grommet.
- 9) Adjust the central against the racquet until it just hits the racquet.

Check if the knobs that fix the posts are tightened!

“Babolat” retainer.

The Babolat retainer is used instead of the normal supports for racquets with a low-profile-bridge.. But it can be used for most racquets if the stringer prefers that.

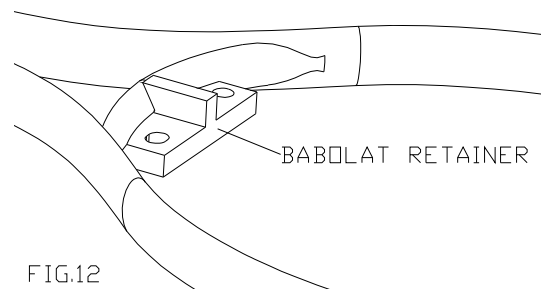

B4. Mounting a badminton racquet (fig. 13).

A badminton racquet is clamped differently from a tennis racquet:

- The racquet is mounted “the other way around” compared with a tennis racquet.
- Higher red badminton supports are used at the head and the throat side instead of the white tennis supports.
- The clamping hooks at the head side are not used to clamp a badminton racquet.
- The clamping piece with the screw is used to clamp the racquet.

The screw must be fixed in the swivel plate and the clamping piece is clamped by tightening the knurled knob.

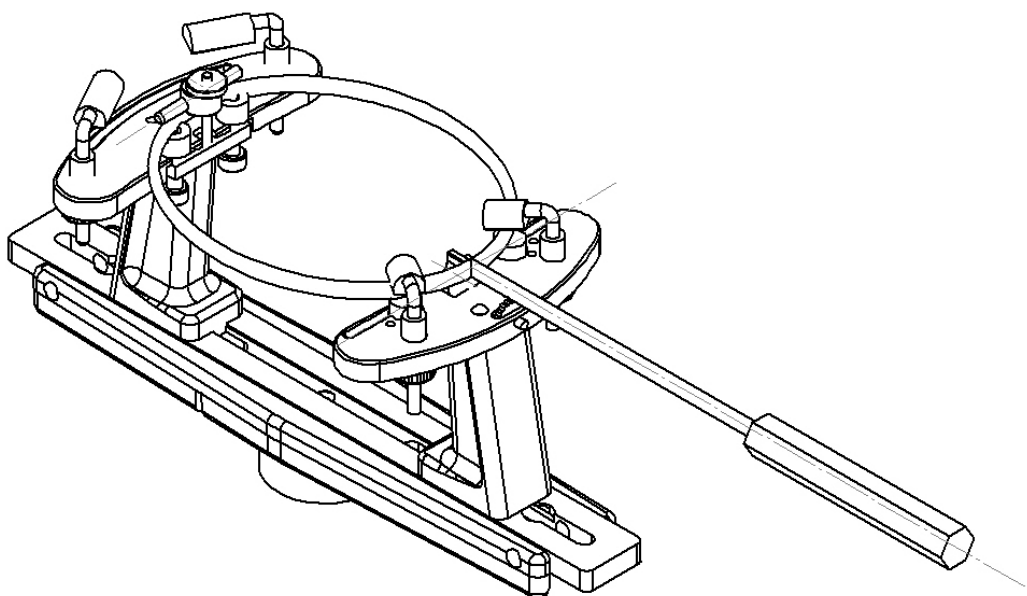

B5. Mounting a squash racquet.

Both support systems can be used for squash racquets, depending on the shape and the height of the profile

B5. Using the table lock.

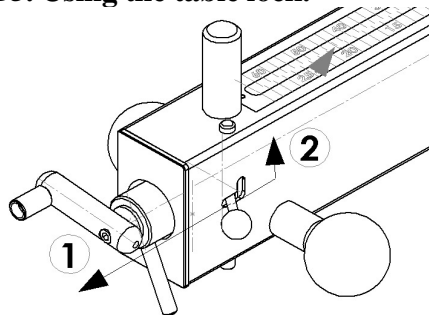

The MS140L has a table lock which locks the turntable in 6 positions. When the lever is in the upper position the table will lock as soon as the locking pin meets a hole in the turntable.

B6. Using the clamp systems.

The MS140 is supplied with flying clamps, there is a double and a triple version of this clamp.

B6a Using flying clamps TH.

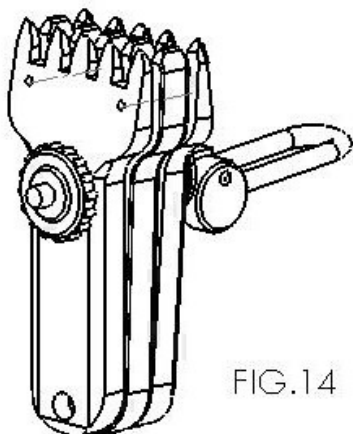

FIG.14

A flying clamp holds the tension by clamping the last string to the string before last.

The knob is used to adjust the clamp to the diameter of the string that is used.

Check the adjustment of the clamps before every string job as

B6d Checking the clamp adjustment.

It is very important to avoid sliding of the strings through the clamps, because that will result in loss of stringbed stiffness.

Therefore it is important to check the adjustment of the clamps for EVERY string job as shown in the figure:

- Hold the string behind the clamp.
- Release the tensioner.
- Check if the string slides through the clamp.

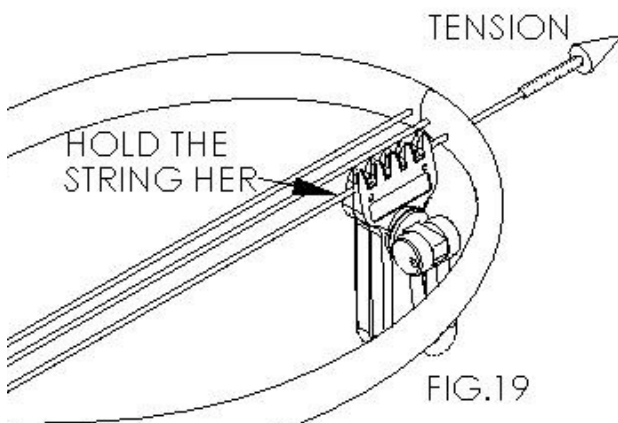

FIG.19

If the string slips through the clamp there can be 2 reasons:

- The clamp is greasy and has to be cleaned. (See D2).
- The clamp has to be adjusted at the diameter of the string and at the tension that is used.

C. OUT OF USE AND TO TRANSPORT THE MACHINE.

C1. Out of use or transporting the machine.

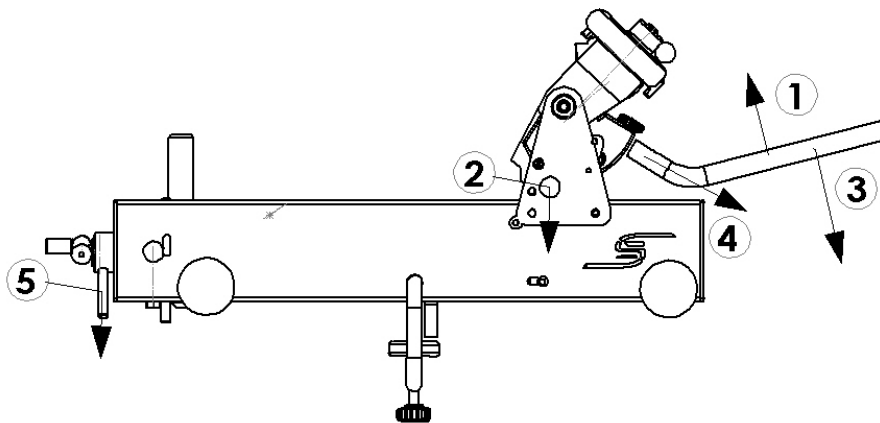

When the machine is out of use or should be transported the tension head should be in the end position against the stop:

- Lift the lever to open the string clamp.
- Push the knob of the locking bar down.
- Lower the lever until the tension head hits the end stop inside the machine.

To remove the lever loosen the clamping knob-screw a little and pull the lever out of the system.

D. THE MAINTENANCE OF THE MACHINE.

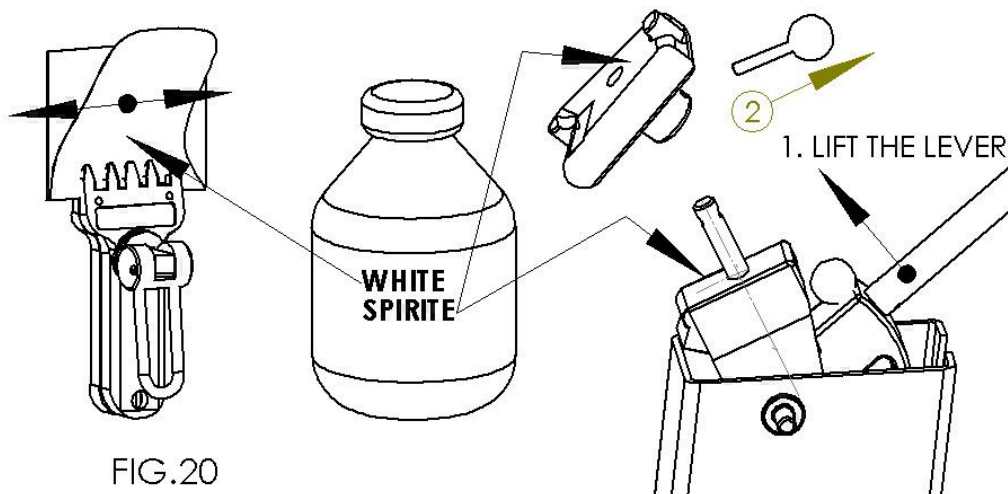

D1. Cleaning the string clamp of the tension unit.

- * Lift the lever so that the string clamp opens and pull the pin out of the upper jaw (2).
- * Pull the upper jaw off the pull rod and clean the surfaces of the string clamp with white spirit.

D2. Cleaning the clamps.

When the string slides through the clamp this can have 2 causes:

1. The adjustment of the clamp is wrong.
2. The silicone coating of the strings has made the clamp greasy, the clamp has to be cleaned:
 - * Fold a cloth around a thin plate and wet it with a degreasing fluid (white spirit).
 - * Move the plate and cloth between the jaws of the clamp, close the clamp and move the cloth and plate up and down between the jaws.

D3. Adjusting and lubricating the turntable.

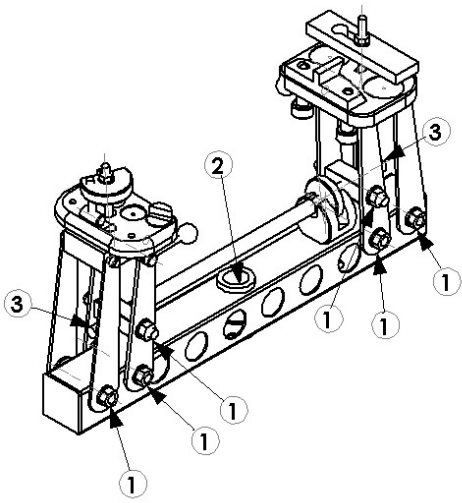

Adjusting the turntable hinges.

If there is clearance in one of the hinges of the turntable guiding arms you can just adjust friction nuts to minimize it.

Lubricating the bearings.

We advice to put some grease on the shaft every now and then for minimum wear.

E. Overhaul of a Stringway clamp.

After extensive use the clamps of the Stringway machines can be overhauled quite easily. Figure 1 shows the parts of the clamp.

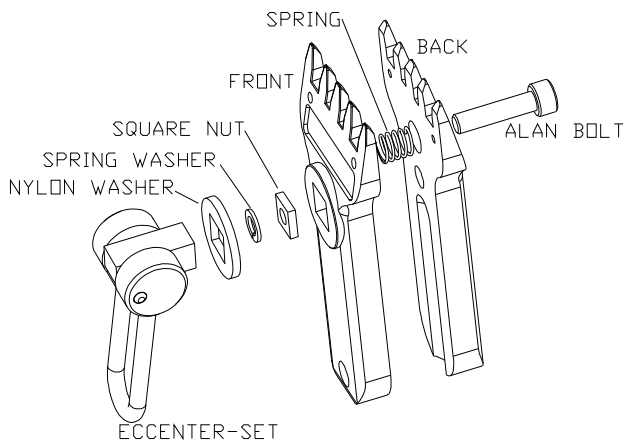

FIGURE 1

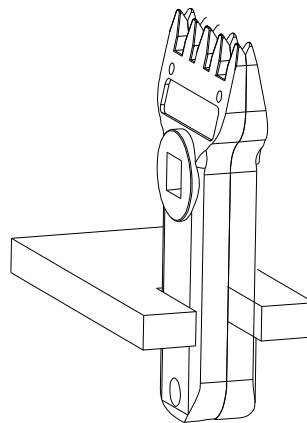

FIGURE 2

DISASSEMBLY

For the disassembly and assembly it is easy to use a vise or a special piece of wood with a slot in it to hold the clamp as shown in figure 2.

To disassemble the clamp unscrew the Alan bolt and take of the closing mechanism.

GRINDING THE CLAMP PARTS.

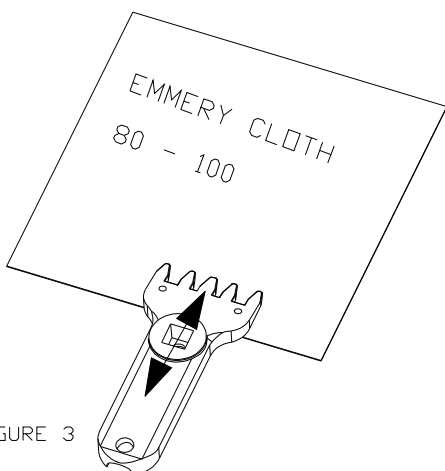

FIGURE 3

To clamp the string with a minimum clamping force the clamping surface must be equally rough. Grind the clamping surface by moving the clamp up and down over a piece of grinding cloth. Support the grinding cloth on a flat surface like a table.

THE ASSEMBLY OF THE

- Put the spring in the hole of the clamp.
- Clamp both castings on top device.
- Put the Alan bolt in from the
- Put the square nut on the into the nut until the nut is clamp.
- Slide the spring washer over

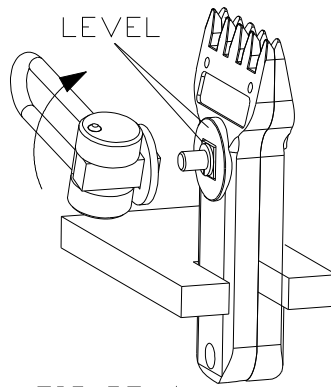

FIGURE 4

- Turn the pull rod of the until it compresses the spring washer completely.
- Turn the pull rod ¼ revolution backwards.
- If the eccentric is in the right position, with the handle downwards, turn the Alan bolt into the pull rod until the nylon washer hits the surface of the clamp.

If the closing mechanism is in the wrong position:

- Unscrew the Alan bolt holding the eccentric, so that the square nut comes out of the hole in the clamp.
- Turn the pull rod / eccentric in the right position.
- Turn the Alan Bolt into the pull rod until the nylon washer hits the surface of the clamp.

GREASING THE CLAMP.

For easy up and down sliding of the clamp it is advised to insert a thick layer of grease into the hollow that clamps the clamp on the pin of the sliding system.

CLAMP.
between the front and the back

of each other in the clamping

back.

Alan bolt and screw the bolt level with the surface of the

the Alan bolt.

eccentric set on the Alan bolt

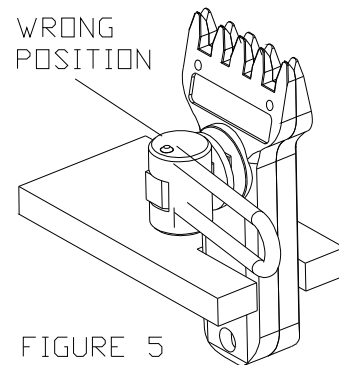

FIGURE 5

We wish you much pleasure with your MS140 stringing machine
